



E-Brake 35T-130T Premium

Press brakes with an E for electronic

Unfold the future



the future
unfolded



Efficiency

The comprehensive solution
for faster production



Ergonomics

Full control of the process
operations with one finger

As the inventor of the electronic press brake, SafanDarley set in motion a world wide Evolution in sheet metal working. Even now, SafanDarley continues to work on innovative ways to raise your efficiency levels.

With SafanDarley, you will be able to operate at the highest possible level from the get-go and benefit from unique innovations and developments, guided by those people who set the standard: the highest possible standard for integrated sheet metal working.



Ecology

Maximum CO2 and oil reduction



Economics

Maximum return on your investment

SafanDarley offers innovative solutions for all varieties of sheet metal working, using game-changing electronic, hybrid and hydraulic techniques.

SafanDarley unfolds a future in which each sheet metal worker can benefit from opportunities to produce in a more Efficient, Economical, Ergonomical and Ecological way. Complex products, large and smaller product ranges: process optimisation and lean manufacturing with zero defects are a given with SafanDarley, and just-in-time production is guaranteed.

Working with SafanDarley means being able to trust us at our word and knowing we will keep our promises: regarding providing technology that sets the standard in industrial sheet metal working; regarding introducing innovations that actually contribute to maximum operating efficiency; and regarding being a partner that actively contributes high-level ideas and solutions to your problems. SafanDarley will allow you to be ahead of the times and secure your competitive position.

Smart production in the Smart Industry

SafanDarley leads the way to smarter production with its new technology and its Smart Industry. Smart Industry is an approach that allows industrial companies to take up a strong position by making maximum use of the newest information and technological developments. We do so by implementing far-reaching digitalisation and more closely linking equipment, production resources and organisations, which results in a new, better integrated way of production. SafanDarley thus ensures production that is more efficient, more flexible, of higher quality and tailor-made.

Put in more concrete terms, 'smart production' means improvement of your OEE or Overall Equipment Effectiveness. We consider your every need to make sure that our machines fit into your production line perfectly. Our purpose in employing our machines, software, data communication, robotisation and human guidance to aid you is to ensure optimisation of your manufacturing processes with zero defects.

Improvement of your Overall Equipment Effectiveness is easy once you have SafanDarley as a part of your production process. To put it more concretely, it is common for companies' OEE to increase by 30%.

SafanDarley enables you to stay ahead of time and safeguard your competitive position.



**SAFAN
DARLEY**
E-Brake 35T-130T Premium



Roller drive with 2 servomotors



**Industry 4.0
READY**



Fully electric

E-Brake Premium

SafanDarley E-Brake Premium

The fourth generation E-Brake adds important new benefits to existing E-Brake technology, which has now proven itself worldwide. E-Brake Premium is the successor to the current E-Brake up to 100T. One key feature is the new design, which significantly improves the ergonomics. The controls are also given a new design and are Industry 4.0-ready, which means that they communicate with external systems. In short, the new generation SafanDarley E-Brake represents the next step in the E-evolution of sheet-metal working.



Over 30% higher
productivity



Uses up to 50%
less energy,
less CO2 emission



No harmful
hydraulic oil

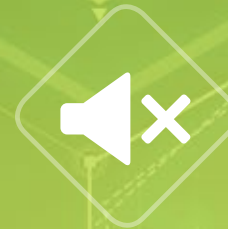

High degree
of noise reduction



Back gauge used
across the full
working length



User-friendly
Touchscreen control

The unique pulley drive of SafanDarley has proven itself around the world

Servo-electronic bending with the E for even bending

The unique, patented roller drive system in the upper beam ensures a uniform and even distribution of forces. A balanced combination of powerful electro-motors, fixed and movable rollers and specially developed belts facilitate capacities of up to 300T.

The flexible belts, which are only 3 mm thick and 50 mm wide, are reinforced with steel wires and coated with hard polyurethane. This advanced technology has been extensively tested in the demanding elevator industry. So reliable is the technology that SafanDarley are able to offer a 5 year warranty on the mechanical drive system,

when combined with an annual service contract. The special construction of the SafanDarley E-Brake also contributes to the even absorption of large forces. The O-frame acts as a single unit and deformation is kept to an absolute minimum. It is more stable, stronger and produces less deformation than a conventional C-frame.

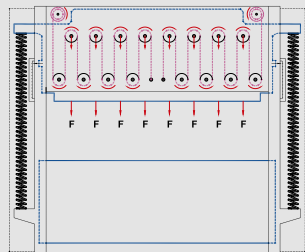

Even distribution of forces

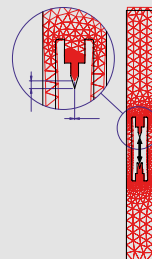

E-Brake

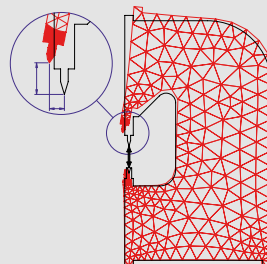

Conventional



E-Brake Premium

Up to 30% shorter cycle times

The new SafanDarley E-Brake Premium has been optimised further in order to profit from the acceleration options and the other convenient servo characteristics. This not only makes the E-Brake very fast in rapid traverse, but also during the full cycle.

The E-Control control system, which was developed in-house, uses a new generation of electronics and software. This results in incredibly short reaction and stop times, through which bending speeds of up to 20 mm/sec can be achieved. Cycle times are also far shorter than with conventional press brakes, partly through the fast backgauge. In comparison tests, the SafanDarley E-Brake is shown to be up to 30% faster than a conventional press brake. Cycle times for this product (see image below):

SafanDarley E-Brake 50T 2050	Cycle time 20 sec.
Conventional hydraulic press brake	Cycle time 35 sec.

Up to 50% energy saving

The SafanDarley E-Brake only uses energy when the top beam is actually moving. This can deliver an energy saving of up to 50% compared with conventional hydraulic press brakes.

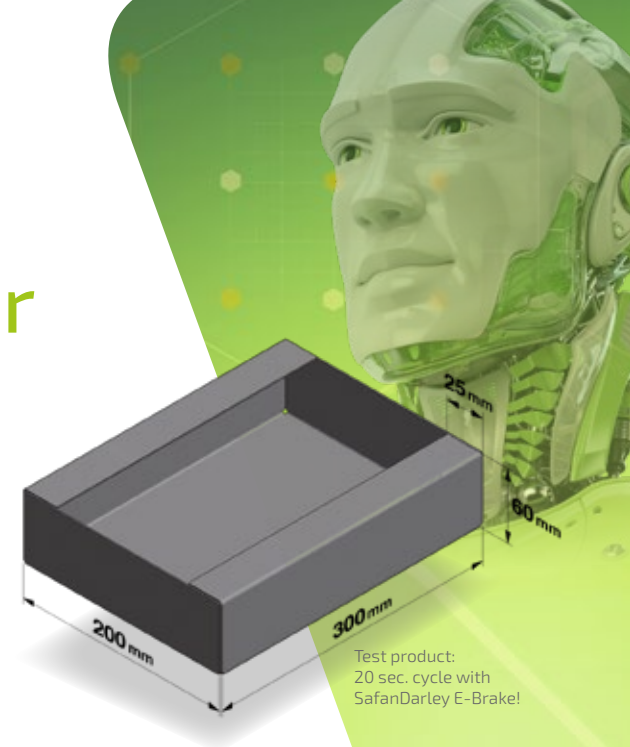

Test product:
20 sec. cycle with
SafanDarley E-Brake!



Bending test product

Innovation with the E for efficiency

After the success of the first generation of E-Brakes and the breakthrough to the heavier segment of 300 tonnes, we have continued optimising the machine concept. What could we improve in the construction and how could we make the machine even more efficient to work with? The answer was found in a modular construction of the E-Brake, a new back gauge, and a longer stroke.

Modular machine concept

The biggest innovation in the SafanDarley E-Brake Premium is in how the machines are constructed. Thanks to the new modular concept, every machine in the range can be produced more efficiently and delivered faster, from the 35T-1250 to the 130T-4100. The standard Q size (Opening) is 590 mm, but you can opt for 650 mm, 690 mm or 790 mm also.

Extremely stable back gauge with CNC controlled X and R axis

A newly designed construction makes the innovative back gauge system of the SafanDarley E-Brake Premium extremely stable. The system is very distinct, as the back gauge spans the entire width of the machine.

In addition, the electronic control system makes it extremely precise (0.02 mm). The back gauge has a traverse speed of no less than 350 mm/sec. The CNC controlled X and R-axis are a standard feature, as are the folding back gauge fingers and 1,000 mm range.

Options

As an option, the back gauge system can be equipped with CNC controlled Z-axis and Delta X-axis.

Tool system

As a standard, the E-Brake Premium comes with the New Standard Pro MC mechanical tool clamp system. As an optional extra, we'll supply the E-Brake Premium with the New Standard NSCL-I HC Premium hydraulic tool-clamping system. You may also select from a wide variety of hardened and/or hydraulic Wila clamps or the European Style tool-clamping system.

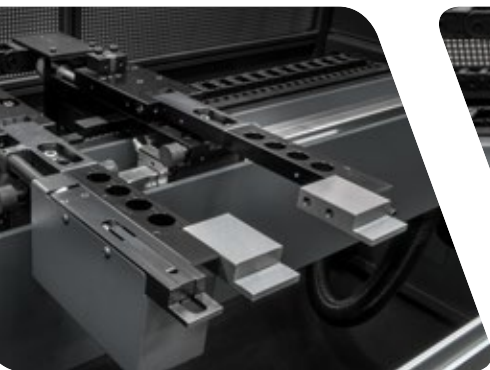
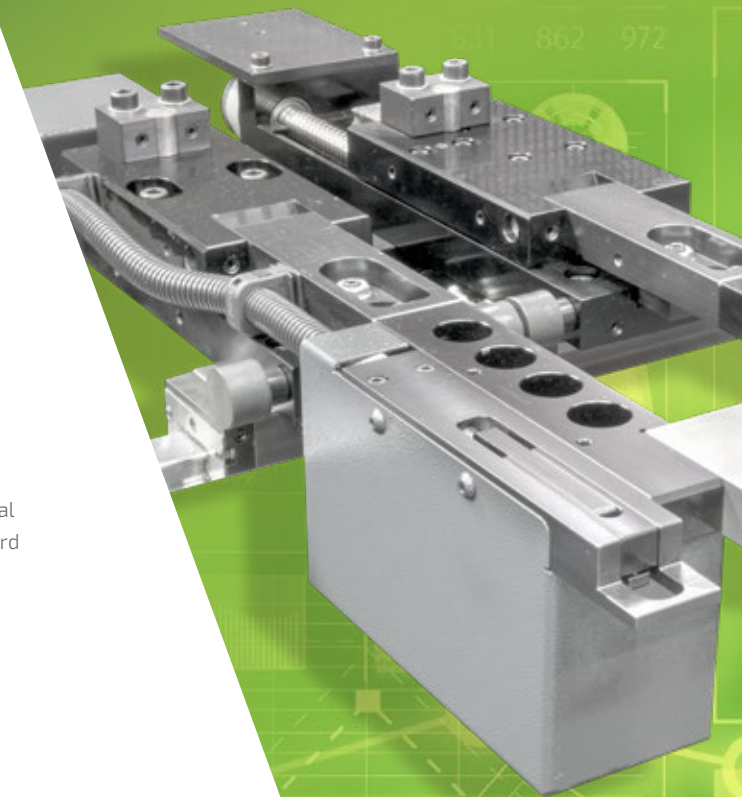

Backgauge with X-, R- and Z1+Z2-axis

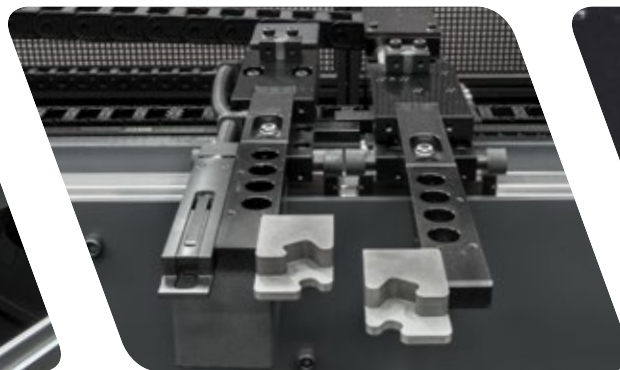

Backgauge with X-, R-, Z1+Z2- and Delta X-axis

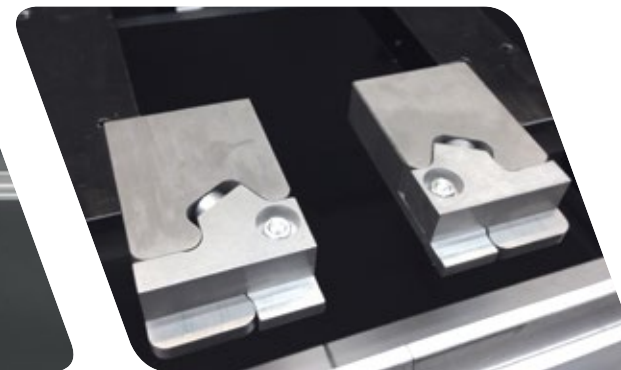

3D stops

Extensive options for client-specific solutions

Moveable and adjustable support arms

SafanDarley has developed a range of support arms of modular construction for both light and heavy-duty sheet-metal work. This makes it possible to rapidly set up the correct solution for each application. This results in a perfect synergy between ergonomics and efficiency.

All support arms can be used in combination with the light guard. The support arms are as standard equipped with brushes. You can choose from the following possibilities:

- Support arms fixed to the machine
- Support arms movable across the front side of the machine
- Support arms movable across the front side of the machine and height adjustable with a handwheel
- Support arms movable across the front side of the machine and pneumatically adjustable in height (programmable on the control)

Optionally all support arms can be equipped with adjustable front stops.



Standard backgauge stops



3D backgauge stops



Movable support arms adjustable in height



Movable support arms

Programming in three steps

01 Importing and unfolding

The software will automatically determine the correct results, optimum bending sequence, stop positions and optimum tool set-up with as few manipulations as possible based on an imported 3D model. You also have the option of adjusting the bending sequence and stop positions manually.

02 Bending simulation

A complete 3D bending simulation allows you to check the entire bending process. A CNC program containing all of the off-set data will then be generated. This powerful software ensures product-accuracy from the get-go.

03 Production

Retrieving the data package from the network using the controls and get going using the press brake. The NC program and the bending simulation will appear on the bottom screen, and other data such as technical drawings, video, notes, etc. will appear on the top screen (this is optional).

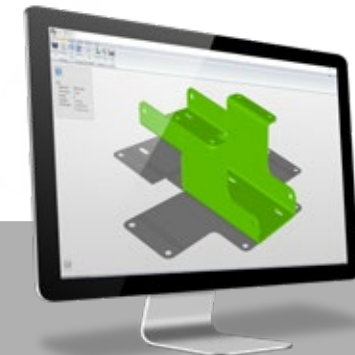

01 Importing and unfolding

Offline 3D-programming

SafanDarley offline 3D programming stands for complete and reliable process management. As opposed to several widely used CAD/CAM systems, our system is very user-friendly and requires only a short 2-day training period.

The design program includes an ingenious simulation and control module for using the press brake that can be remote-controlled, from the office for example. This limits the time during which the machine is at a standstill, thus maximising productivity.

The system consists of 3 simple steps. Fast and flawless work is the SafanDarley standard.

Offline programming offers you plenty of ways to do 3D Design and to import and correctly produce 3D drawings. If the employee using the program is also the one controlling the press brake, an NC code for the system may be generated instantly. The program will then select the necessary tools and optimise the machine. A work planner can even switch to a different press brake at the last moment, re-generate the NC code and run a collision check.

To conclude: optimum streamlining of your manufacturing processes. Even when used in conjunction with other CAD and CAM systems.

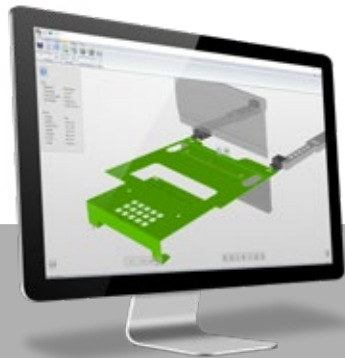

02 Bending simulation



03 Production



SafanDarley E-Control, the new E-standard in ergonomics

Since the introduction in 1995, the SafanDarley E-Controls have been the international standard for ease of operation. The touch screen concept is therefore the most functional and intuitive Man-Machine interface in the sheet-metal working industry.

We have once again shifted the standards with the SafanDarley E-Control as the latest generation touch screen controls.

Complete Touch Screen convenience

The SafanDarley E-Control is fully touch screen, whereby the only buttons visible on the 21" screen are those that are needed during operation. The controls simply run on a PC under Microsoft Windows®, the software was developed based on Microsoft.net Framework. The unit is fitted with a 100 MB Ethernet UTP network connection as standard. The instructions are transmitted to a central processor from the SafanDarley E-Control controls, which in turn regulates the various axis via a so-called CAN-BUS (Control Area Network). The system can be programmed quickly and accurately thanks to a 'self-teaching' database with data on materials, tools and previous, already corrected bending. The SafanDarley E-Control can be coupled to the majority of off-line programming systems.

E-controls

The E-Brake Premium is fitted as standard with E-control EC10 controls on a single split-screen

display. This functionality allows the user to run two applications on a single display, enabling you to create a paperless working environment using the EC10 controls. The machine may also be optionally fitted with EC20 controls. This enables both numeric and 2D-graphic programming. It is possible to draw a complete product by means of touch screen and to then automatically generate a bending program. The developed length is also calculated.

Web-based communication and support

The controls are set-up for web-based communication such as online diagnosis and loading software updates via the web. Machines can also be coupled to each other in a group and tooling databases can be shared. By monitoring and analysing your operating data online, SafanDarley will be in a position to optimise your production process remotely in the near future.



Real time connectivity

Summary of EC10 and EC20 SafanDarley press brake controls

Type	Possibilities	Can be controlled offline with
EC10	<ul style="list-style-type: none"> • Colour Touch screen 21" • Numerical programming of products by means of Touch Screen • Numerical display of bending parameters • Use of up-to-date database 	SafanDarley EC software <ul style="list-style-type: none"> • Delem Profile • Delem V Bend • Autopol • Radan
EC20	All of the EC10 features as well as the following: <ul style="list-style-type: none"> • 2D and 3D graphic display of products programmed offline for Autopol and Radan • 2D Programming of products using Profiler • Automated bending sequence calculation Bending simulation 	SafanDarley EC Software <ul style="list-style-type: none"> • Delem Profile • Delem V Bend • Autopol • Radan

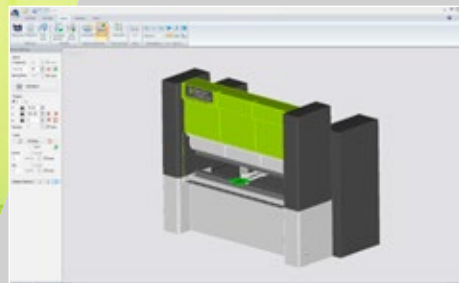

Off-line 3D programming (Autopol)



2D bending instructions (EC20)



2D programming (EC20)



Bending with an E for efficient options

Fast, simple and reliable sheet thickness measurement can be essential for your bending process. SafanDarley has made E-evolutionary advancements in this area too. The SafanDarley E-Bend system, electronically interfaced to the E-Control Touch Screen controls, gives you greater efficiency with precise measurements of sheet thickness.

SafanDarley E-Bend S

The SafanDarley E-Bend S sheet thickness measurement system is mounted next to the backgauge finger. The system measures the sheet thickness to an accuracy of ± 0.01 mm. It can be precisely programmed when measurement should take place. Measurement takes just tenths of a second and the data in the control system is immediately adjusted. The control system database maintains all records of measurement and is set out graphically.



SafanDarley E-Bend S

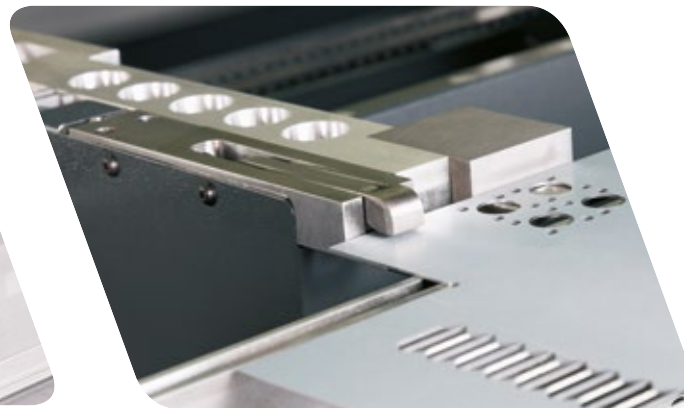

Increase your efficiency with exact sheet thickness measurements.

SafanDarley E-Mate bending aids

With the electrically-driven E-Mate bending aids from SafanDarley, you prevent angle deviation when bending thin sheets with large dimensions. The bending aid provides the operator with a simple and ergonomic means to remain within set angle tolerances.

It is often not easy for an operator to position large sheets. Certainly during the return movement of the top beam, it is difficult work to keep everything in hand. Instead of having a second operator provide assistance, it is frequently more efficient to install a SafanDarley bending aid. In most cases, it can be used by a single operator to position larger products. In brief, along with accuracy, productivity is increased by the SafanDarley E-Mate, the best partner for your operator. In order to relieve the operator in the case of long, routine, heavy

duty work, SafanDarley has developed an extremely powerful and highly accurate bending aid, the E-mate plus. The bending aid supports and follows the sheet with great accuracy throughout the entire bending process.

Type of bending aid	Max. sheet weight
• E-Mate	30 kg.
• E-Mate plus	150 kg.



SafanDarley E-Mate bending aid



SafanDarley E-Mate Plus bending aids



The E-standard for Ecology



SAFAN
DARLEY



Electronic evolution with an E for ecological and economical

The SafanDarley E-Brake contributes perfectly to your sustainable business, while at the same time making your business operations much more economic. The absence of hydraulics means that the problems associated with environmentally harmful and risky oil are a thing of the past. No overpressure valves need to be set – with a chance of errors and narrowing – and no filters need to be checked and replaced. The servo-electronic system is therefore much more reliable than the hydraulics, due to the lack of oil, tank, pump, seals, valves, and filters. You'll never have to deal with a cold start.

Integrated safety

Work fast without risk: SafanDarley makes that a reality with the safety system integrated within the controls. It works with a safety light screen that is automatically directed from the SafanDarley E-Controls. In addition, the SafanDarley E-Brake Premium has an additional in-built safety provision. The application of a spring return means that the top beam will always move upwards in the event of a failure.



E-Brake Premium with an integrated safety system

E-Brake 35T-40T Premium

With the Ergonomic design of the E-Brake, SafanDarley enables the operator and the press brake to work as a unit. The operator is partially seated inside the machine, surrounded by an edging table with his legs in a spacious cut-away underneath the lower beam, where the foot pedal is located. The ergonomic ease of operation is assured as the seating position can be adjusted as desired. The height and angle of the foot rest is also adjustable. All actions of the bending cycle take place in one fluent sequence, as a result of which the shortest possible cycle times can be achieved.

Faster production of larger series

Particularly when bending large quantities, it is an advantage to be able to work sitting down. The sophisticated ergonomic facilities of the Ergonomic model enable the operator to maintain a high output for a long time. This increases the productivity.

Flexible concept

The seating position and the foot rest are adjustable, and the edging table can also be adjusted in four parts. This will enable you to achieve the perfect pick-up height, working height and cast-off height every time. In addition, the edging table can be fully or partially collapsed, enabling the operator to bend whilst standing up. Finally, the entire edging table can easily be removed from the machine to make the front freely accessible. This allows you to use the E-Brake Ergonomic for larger sheet-metal work like you would a "regular" machine, making use of the support arms.

Integrated security

The E-Brake Ergonomic has a double-function safety light screen that is integrated into the control panel. Its first function is to secure the bending zone, its second function allows the axis to move while the operator turns, picks up or removes the product. These simultaneous actions of the operator and machine lead to lightning-fast cycle times, with the highest level of safety. Particularly in the serial production of small parts, this integrated system facilitates an unrivalled work speed with optimum ease of operation.

Man & Machine as one unit



Energy consumption

On the SafanDarley E-Brake Premium, the main drive motor is used only when the E-Brake has to actually perform a movement. With a conventional hydraulic press brake, the hydraulic pump motor is running all the time.

Standard features

- EC10 controls, single split-screen display
- CNC-controlled R- axis
- CNC-controlled Y1-Y2 axis (top beam inclination adjustable +/- 2.5 mm)
- CNC-controlled back gauge (X-axis) with a wide range
- Manual variable adjustment of back gauge fingers width across a linear guide
- NSCL I MC Pro upper-tool adapter and OB/S-3 lower table with mechanical clamps for New Standard Style tooling
- Z1/Z2 axis, manually adjustable on a linear guide
- Opening size of 590 mm (Q-dimension)
- 2 Support arms (300 mm in length)
- 1 Hold to Run operating console
- Programmable and integrated safety light guard
- Front-mounted tool lighting
- Safety in conformance with CE

Tool adapters SafanDarley E-Brake

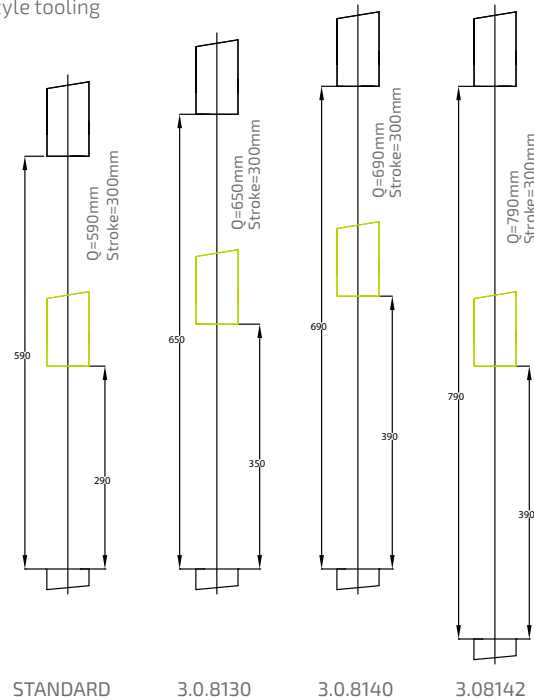
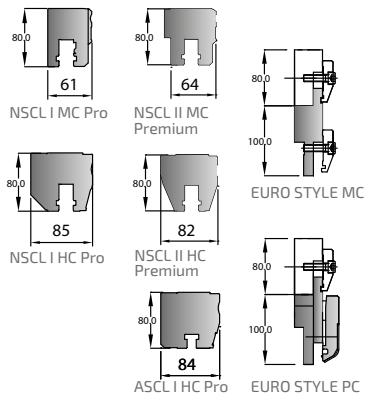

OPERATOR SIDE

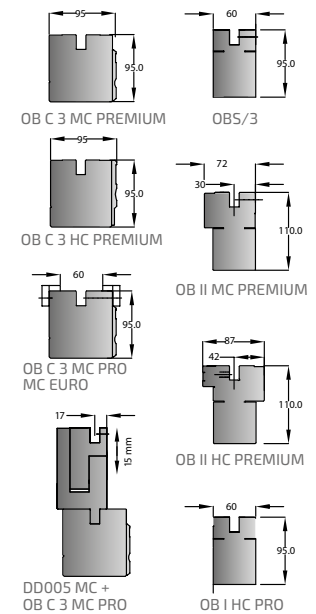

SafanDarley E-Brake energy consumption

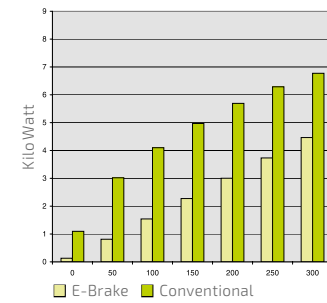

The graph only covers the time while the press brake is actually in operation. During the standby time - which can be as much as 90% on account of sheet handling, machine set up and intervals - this will mean a further saving with the E-Brake up to 3000 kWh a year.



Technical specifications

E-Brake 35T-130T Premium

	Pressing force in kN	Working length in mm	Maximum stroke in mm	Q-dimension in mm	Closing speed in mm/sec	Bending speed max. in mm/sec	Return speed in mm/sec	Motor Power in kW	Weight in kg	A in mm	B in mm	C in mm	D in mm
35-1250	350	1275	300	590	180	20*	180	11	4900	1275	2500	2515	2680
40-1600	400	1530	300	590	180	20*	180	11	5400	1530	2850	2515	2680
50-2050	500	2040	300	590	160	20*	160	11	6100	2040	3300	2515	2680
80-2550	800	2550	300	590	90	20*	90	11	6900	2550	3800	2515	2680
100-3100	1000	3060	300	590	75	20*	75	11	7500	3060	4350	2515	2680
130-3100	1300	3060	300	590	110	20*	110	15	9300	3060	4350	2715	2880
130-4100	1300	4080	300	590	110	20*	110	15	11200	4080	5350	2715	2880

* In CE Version max. bending speed 10 mm/sec
Subject to modifications.

Accessories (optional)

- CNC-controlled Z1-Z2 axis (horizontal repositioning back gauge fingers)
- CNC-controlled Delta X-axis (horizontal repositioning of one back gauge finger)
- Opening size increase up to 650 mm, 690 mm or 790 mm (Q-dimension)
- Various upper and lower tool adaptors
- Various bending aids
- SafanDarley E-Bend S sheet thickness measurement system
- Ergonomic model for E-Brake 35T and 40T
- Various support arms, fixed, moveable and adjustable in height where required
- Extra Hold To Run operating console (compulsory with 2 machine operators)
- Integrated tool cabinet
- Machine lighting
- EC20 2D-graphic CNC controls, single split-screen display

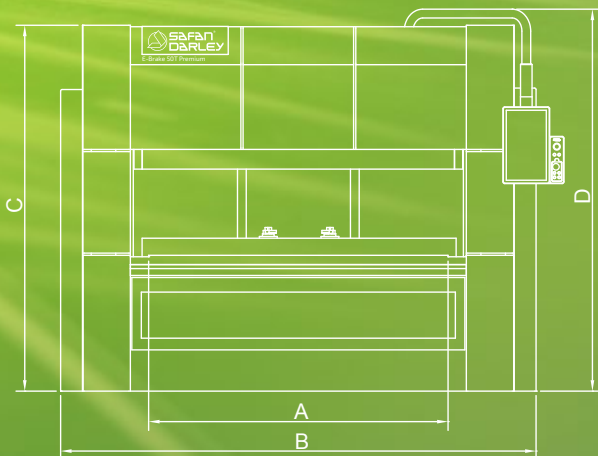
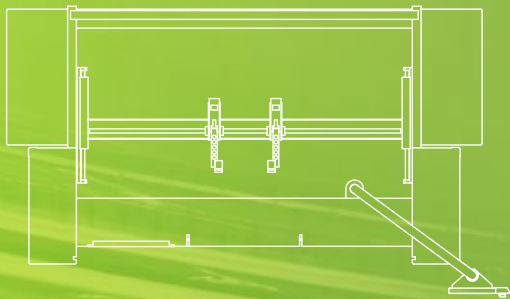
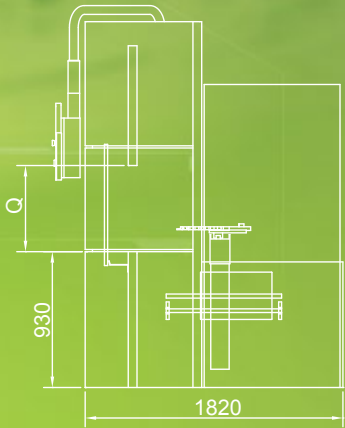



Watch our corporate movie here:



E-Brake 35T-40T
Premium Ergonomic



E-Brake 35T-130T Premium



E-Brake 50T-130T Ultra



E-Brake 160T-200T Ultra



E-Brake 300T Ultra Dual Drive



E-Brake 35T Mini Cell



E-Brake 160T-200T ITC



H-Brake Hybrid 110T-1600



H-Brake Hybrid 110T-170T
Premium



H-Brake Hybrid 110T-170T
Ultra



H-Brake 175T-400T
Ultra



H-Brake HD 500T-1250T
Ultra



R-Brake 130T



B-Shear & M-Shear



Special cutting lines

SafanDarley B.V., Kwinkweerd 11, NL-7241 CW Lochem | P.O. Box 96, NL-7240 AB Lochem
Tel.: +31 (0)573 222 222, Fax: +31 (0)573 222 299 | E-mail: info@safandarley.com | Website: www.safandarley.com